



SP5535 OptimusSBT™

OptimusSBT™ is a compact portable data terminal equipped with Bluetooth® technology to provide the flexibility of batch or real-time data transfer for retail or light warehousing applications, including inventory and stocking.

Bluetooth is becoming more and more popular as a wireless technology for a variety of consumer and business devices, from phones to printers to laptops and more. In order to give users the flexibility to communicate with these devices, Metrologic offers the OptimusSBT. This portable data terminal (PDT) combines the look and feel of the standard OptimusS with the power of Bluetooth technology to open up even more opportunities for customer integration. Connect quickly to Bluetooth printers for quick transfer of records, or even setup applications with a Bluetooth host PC to enable real-time transfer of data for up to the second accuracy of stock/inventory information.

The OptimusSBT comes with a variety of intuitive software programs to simplify the process of batch and real-time application development. The Optimizer software allows fast setup of PDT programs, and the DataOptimizer makes wireless real-time data transfer a snap by quickly taking existing databases and setting them up for use with the OptimusSBT.

With the flexibility of several types of Bluetooth emulation, as well as long range communications, the application possibilities with the OptimusSBT are endless. A rechargeable battery also helps to minimize downtime to allow for faster, more efficient data collection. These features coupled with a compact, sleek design make Metrologic's OptimusSBT a must have for data collection needs in the retail or light warehousing space.

www.metrologic.com



FEATURES

- Class 1 Bluetooth Technology
- Fully charged battery lasts approximately 36 hours
- Several Programming Options (Optimizer, DataOptimizer, BASIC, C)

BENEFITS

- Industry standard technology allows real-time transfer of data approximately 100 meters to a variety of devices
- Lower power consumption than other wireless technologies allows for more uptime
- Cost-effective alternative to WiFi

Minimizes customer down time; speeds up the inventory process

Variety of software allows programmers and non-programmers to setup applications quickly and easily, including wireless applications with existing databases

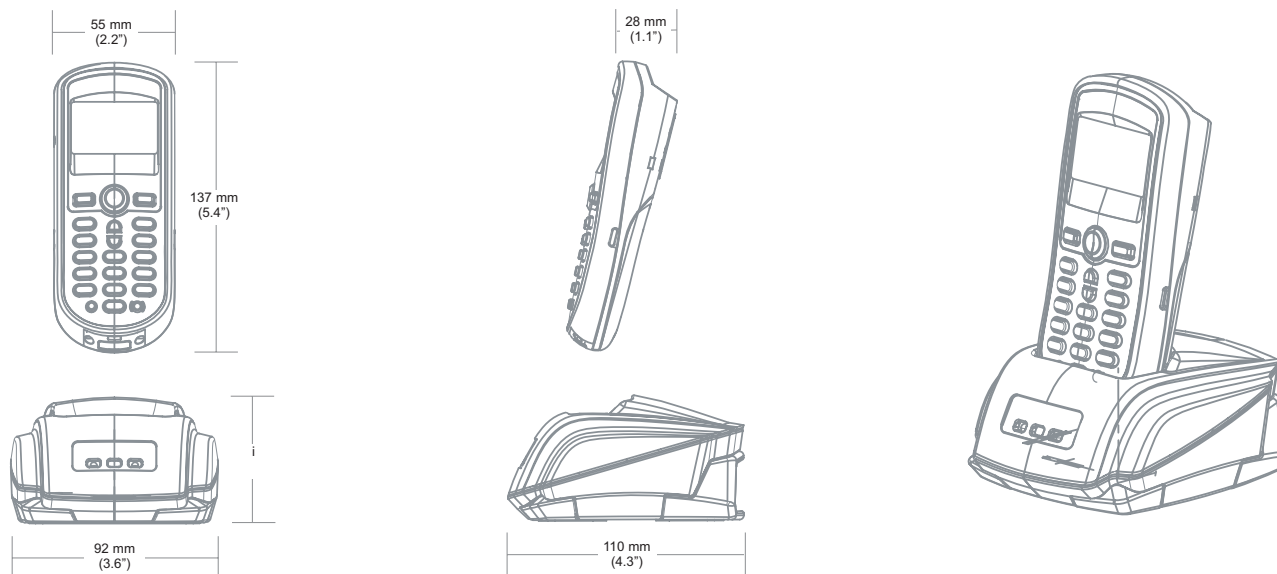

OPERATIONAL

System	
CPU	16-bit CMOS, low power consumption
Program Memory	1 MB flash ROM
Data Memory	2 MB SRAM
Display	LCD - 100 x 64 pixels, back-lit
Resolution	8 lines x 16 characters (max), 4 lines x 12 characters (min)
Bluetooth versions	1.2
Bluetooth profiles	Bluetooth Network Encapsulation Profile (BNEP), Serial Port Profile (SPP)
Communication (Unit)	Cradle IR or Bluetooth (Class 1)
Communication (Cradle)	RS232, USB
Application Development	Windows-based Optimizer; optional C & BASIC compilers

MECHANICAL

Weight	140 g (4.9 oz) - including batteries
--------	--------------------------------------

ELECTRICAL

Battery Operation	Li-ion
Battery Backup	3.7V, 700mA hours, rechargeable lithium battery
Operation	Over 36 hours
EMC regulation	FCC Class A, CE and C-Tick approved

ENVIRONMENTAL

Operating Temperature	0°C to 55°C (32°F to 131°F)
Storage Temperature	-20°C to 60°C (-4°F to 140°F)
Humidity	5% to 95% relative humidity, non-condensing
Shock resistance	1.2 m (4") drop onto concrete

SCAN PERFORMANCE

Laser Scanner	
Visible Laser Diode	650 nm
Minimum Bar Width	0.127 mm (5.0 mil)
Width of Scan Field	290 mm (11.4") @ 222 mm (8.75")
Depth of Scan Field	20 mm - 202 mm (.75" - 8.75") for 0.33 mm (13 mil) bar codes
Scan Speed	100 scan lines per second
Print Contrast	35% minimum reflective difference

Scan Area

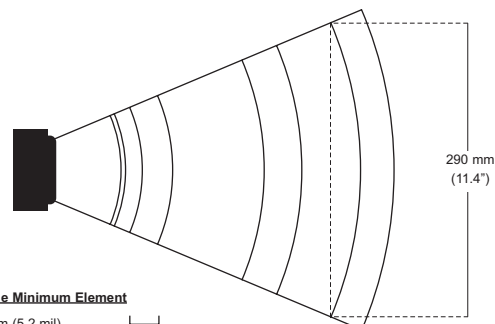

Bar Code Minimum Element

0.132 mm (5.2 mil)	0 mm (0")
0.190 mm (7.5 mil)	64 mm (2.5")
0.264 mm (10.4 mil)	127 mm (5")
0.330 mm (13 mil)	191 mm (7.5")
0.495 mm (19.5 mil)	254 mm (10")
	318 mm (12.5")

Product Colors Available



Optimus is available in a variety of other colors with minimum quantity purchase



Sunrise 2005 Compliant



www.metrologic.com
ISO 9001:2000

Metrologic Instruments, Inc. | **Worldwide Headquarters**
90 Coles Road | Blackwood, NJ 08012-4683 | info@metrologic.com
Telephone 856-228-8100 | Fax 856-228-6673

Asian Headquarters Tel. 65.6842.7155 info@sg.metrologic.com	European Headquarters Tel. 49.89.89019.0 info@eu.metrologic.com	The Americas Headquarters Tel. 1.800.ID.METRO info@us.metrologic.com
--	--	---

Specifications subject to change without notice.
Printed U.S.A., Copyright March 2006
Metrologic, All rights reserved.



DS5535